

**PROTOTYPE**<sup>™</sup>  
BICYCLE RACING PARTS

20  
24



# COMPANY

## About us

### We test what we do!

The performance, efficiency and reliability are our base work priorities. Though lightweight, the stiffness of PROTOTYPE products are tested through a computationally intensive process to the limit, proven by elite athletes who have won more than 100 national and international titles, including the World Champion.

PROTOTYPE is totally committed with after sales support, giving technical solutions to allow find practical and simplified options.

We know where we are and where we want to go.

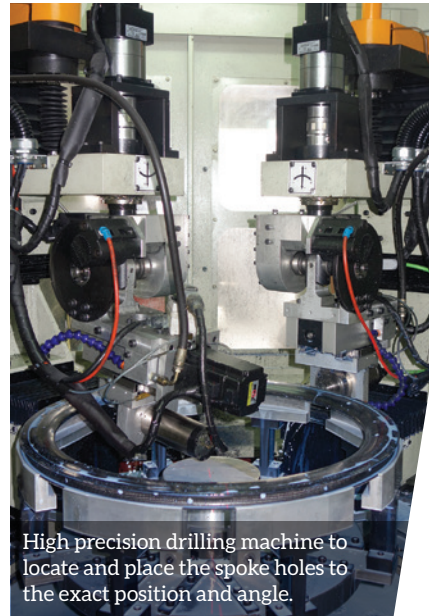

High precision drilling machine to locate and place the spoke holes to the exact position and angle.

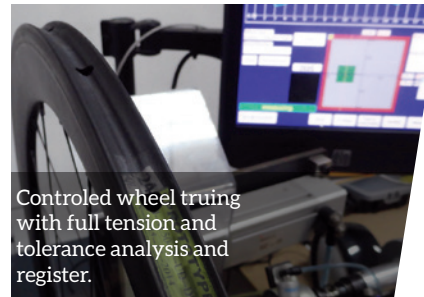

Controlled wheel truing with full tension and tolerance analysis and register.

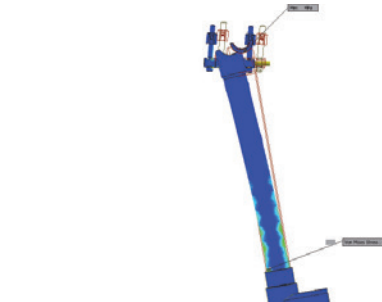

Finite element analysis (FEA) to calculate stresses and displacements of component displacements, strains under internal and external loads.

With the analysis results, we can catch design flaws and optimize features at the drawing stage.

CHAMPIONS  
ARE POWERED  
BY PROTOTYPE





*All wheels are built with unmatched attention to detail, we use high-precision tools, specially designed by us. We can offer a ride quality and durability that cannot be matched by a stock machine-built set.*

**Ivo Santos**

Prototype Technical Department



# MTB WHEELS

**The perfect  
combination for fun  
and performance**

These fast and light  
products are all about  
responsiveness and  
efficiency due to our  
constant research  
and development





# CROSS COUNTRY WORLD CUP SP

M T B



### RIM Detail

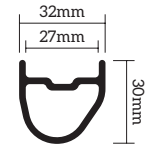

ASYMMETRIC  
HOOKLESS

### HUB Detail



DECAL Option



BLACK

Reference weight:  
Clincher: 29" EVO 4 SP Boost - 1410gr

MSRP: 1.890 €

**i** See more details  
on page 20.

# CROSS COUNTRY CARBON SL

M T B

### RIM Detail

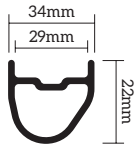

ASYMMETRIC  
HOOKLESS

### HUB Detail



Reference weight:  
Clincher: 29" Boost - 1290gr

MSRP: 1590 €

**i** See more details  
on page 20.

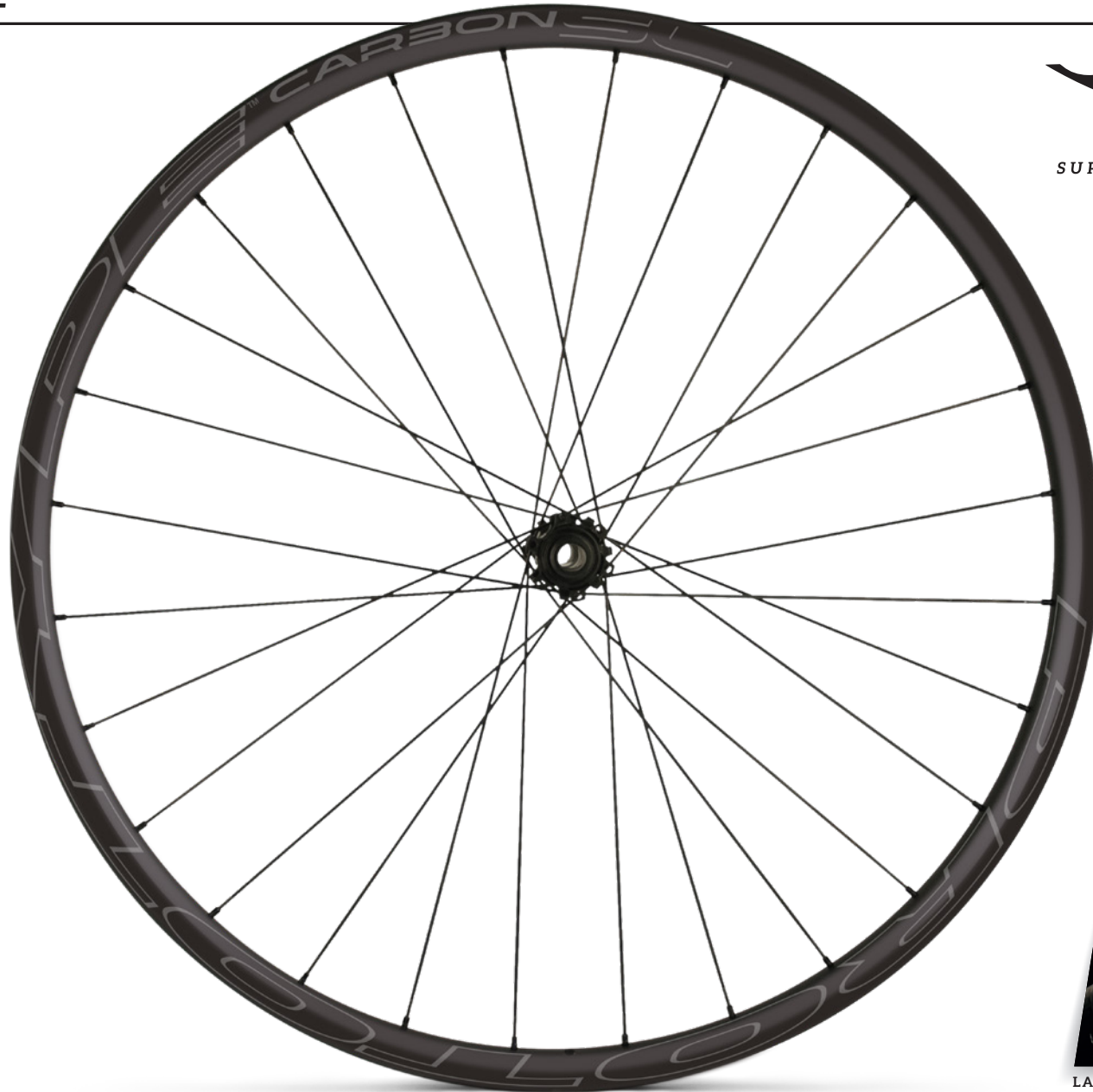

SUPER LIGHTWEIGHT

### Laser Detail



LASER

M T B

# CROSS COUNTRY CARBON ZERO



### RIM Detail

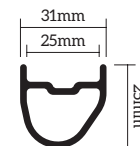

ASYMMETRIC  
HOOKLESS

### HUB Detail



DECAL Option



BLACK

Reference weight:  
Clincher: 29" Boost - 1560gr

MSRP: 1065 €

**i** See more details  
on page 20.



# CROSS COUNTRY RW

M T B

RIM Detail

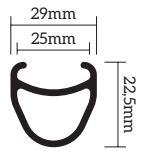

SYMMETRIC

HUB Detail



Reference weight:  
Clincher: 29" Boost - 1690gr

MSRP: 565 €

**i** See more details  
on page 20.

Also available in 27,5"



DECAL Detail



M T B

# ENDURO & E-MTB FLASH CARBON

REAR HUB OPTION  
Extreme



RIM Detail

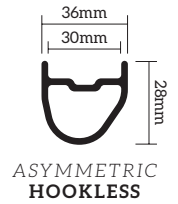

HUB Detail



DECAL Detail



Reference weight:  
Clincher: 29" Boost - 1680gr

MSRP: 1.285 €

**i** See more details  
on page 20.

Also available in 27,5"

# ENDURO & E-MTB FLASH AL

M T B

### RIM Detail

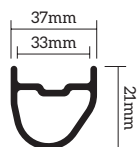

ASYMMETRIC  
HOOKLESS

### HUB Detail



REAR HUB OPTION  
Extreme

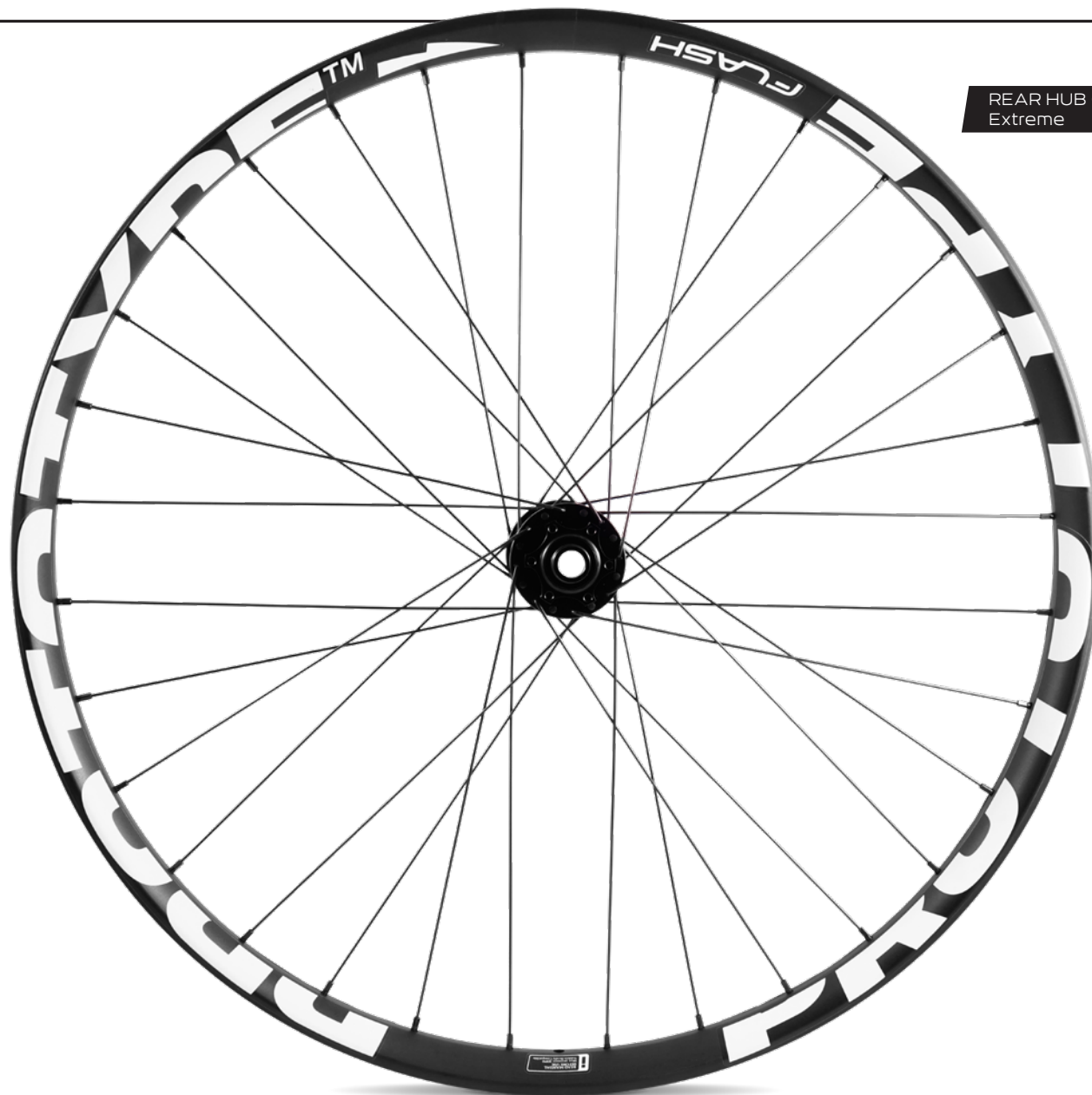

Reference weight:  
Clincher: 29" Boost - 2020gr

MSRP: 645 €

**i** See more details  
on page 20.

Also available in 27,5"



# ROAD WHEELS

**Prototype is the answer when a racer is looking for the best performance**

We have the finest combination of light, stiff and aero wheelsets, developed in partnership with professional athletes



# WORLD TOUR 5

R O A D

### RIM Detail

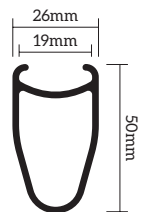

TUBELESS  
OPTIMIZED

### HUB Detail



### Bearings

**ULTIMAX  
CERAMIC**

Optional

Reference weight:  
Clincher: 1560gr

MSRP: 1690 €

**i** See more details  
on page 21.





R O A D

# WORLD TOUR 3



### RIM Detail

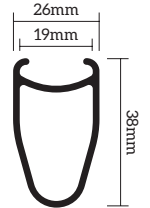

TUBELESS OPTIMIZED

### HUB Detail



### Bearings

**ULTIMAX CERAMIC**

Optional

Reference weight:  
**Clincher: 1430gr**

MSRP: 1690 €

**i** See more details on page 21.



BLACK



# PRO TOUR DISC 5

R O A D

RIM Detail



HUB Detail



LIFETIME WARRANTY

NEW HUB

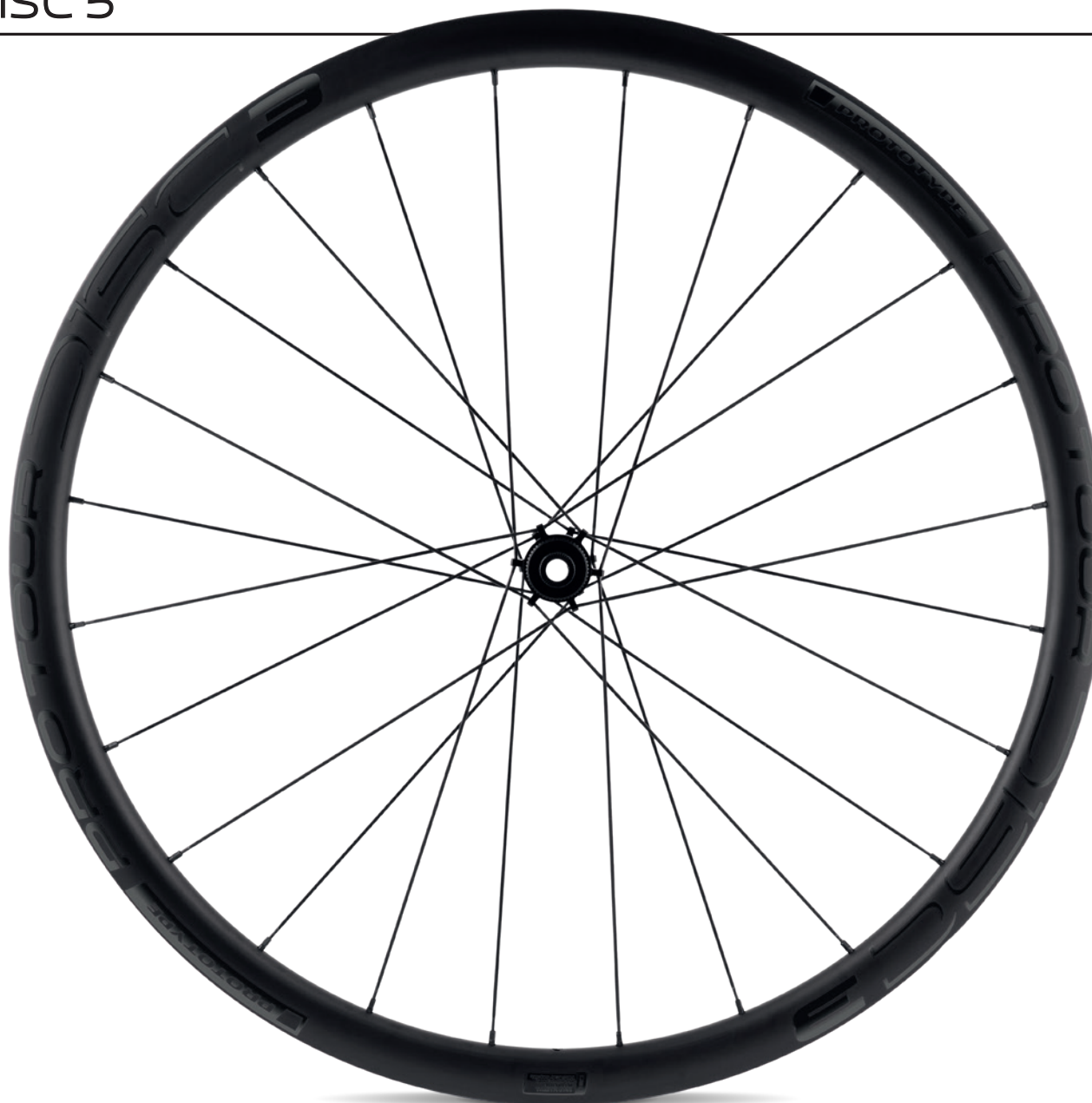

Reference weight:  
Clincher: 1590gr

MSRP: 1080 €

**i** See more details on page 21.

R O A D

# PRO TOUR DISC 3



RIM Detail

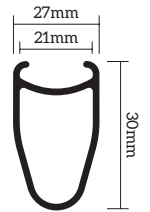

HUB Detail



NEW HUB

Reference weight:  
**Clincher: 1460gr**

MSRP: 1080 €

**i** See more details  
on page 21.

# WHEELS TIME TRIAL TRIATHLON



**The Joker wheelset is the choice for pros racing against the clock**

From the Time Trial, Olympics Games to pro Ironman races, it's a proven route to the top step of the podium



TIME TRIAL TRIATHLON  
JOKER DISC

WHEELS ROAD



Reference weight:  
Climber: 1180gr  
MSRP: 1475 €

**i** See more details  
on page 23.



# GRAVEL WHEELS

## It's a new era of wheels

The Prototype Gravel specific carbon fiber is designed to withstand the hardest terrain. The tire bed is capable of resist frequent installations and removals.



GRAVEL

---

CRATER AERO

---

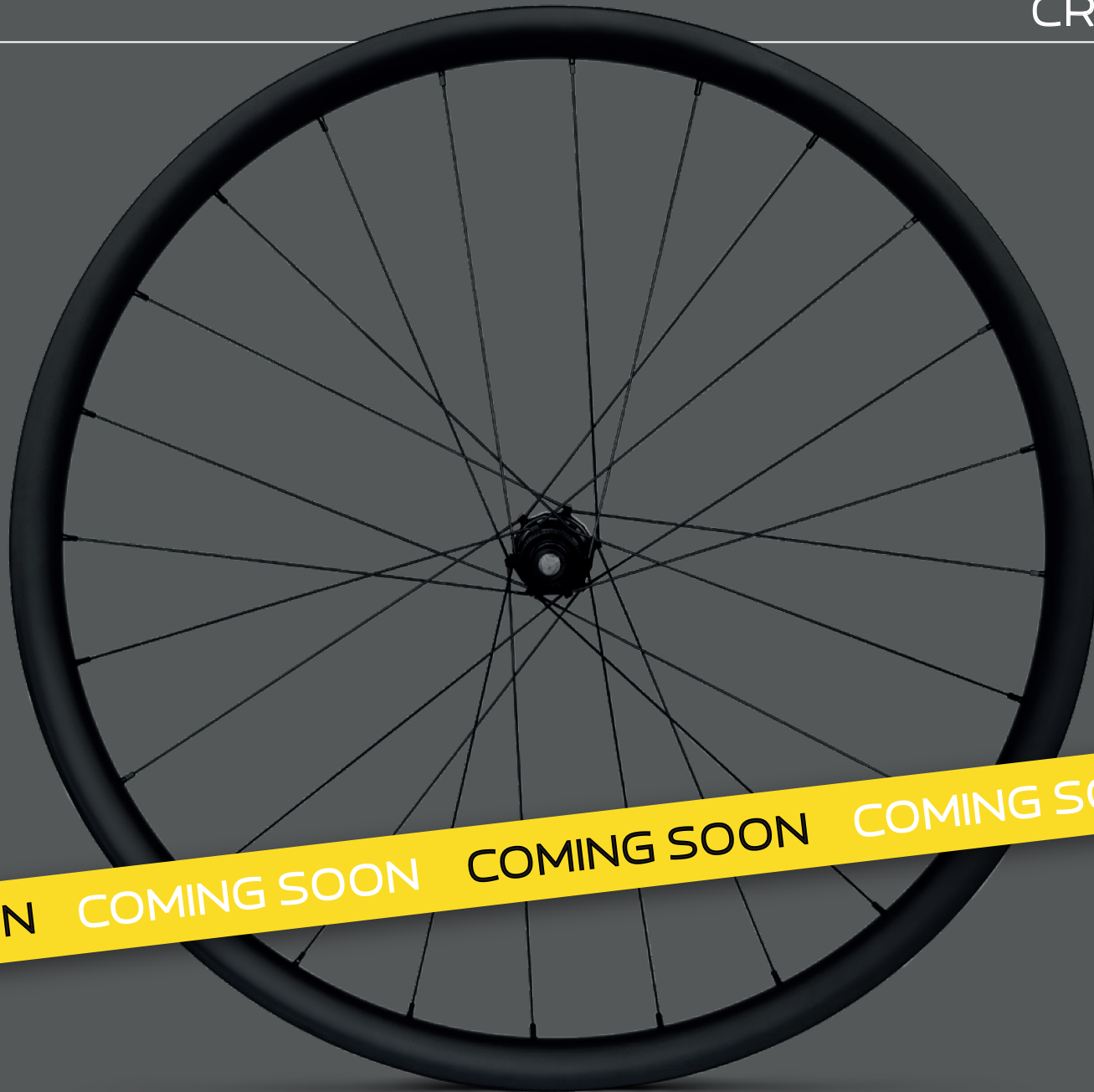

COMING SOON COMING SOON COMING SOON COMING SOON COMING

**NEW**

# CRATER CARBON

GRAVEL

RIM Detail

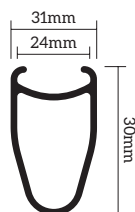

HUB Detail



LIFETIME WARRANTY

**NEW HUB**



Reference weight:  
Clincher: 1395gr

MSRP: 1090 €

**i** See more details on page 22.



## TECHNICAL SPECIFICATIONS MTB WHEELS

	World Cup SP	Carbon SL	Carbon Zero
<b>Rim Material</b>	Full Carbon	Full Carbon	Full Carbon
<b>Rim Width Inner/Outer</b>	27/32	29/34	25/31
<b>Profile</b>	30	25	25
<b>Tire Size / Width</b>	29" / 2.0 to 2.5	29"	29" / 2.0 to 2.5
<b>Tire Type</b>	Tubeless ready	Clincher	Tubeless ready
<b>Spoke</b>	Aero SL 2.0 - SP	Round - J Bend	Round - J Bend
<b>Nipple</b>	Aluminium	Aluminium	Aluminium
<b>Hub Model*</b>	EVO 4 SP	EVO 4 SP	FSL 3.0
<b>Freewheel Body</b>	SH 11 / XD / Micro Spline	SH 11 / XD / Micro Spline	SH 11 / XD / Micro Spline
<b>Braking</b>	Disc Brake IS	Disc Brake IS	Disc Brake IS (6 bolts)
<b>ASTM **</b>	3	3	3
<b>Discipline</b>	XCO / XCM	XC	XCO / XCM
<b>Weight Limit</b>	100kg	90kg	100kg
<b>Weight (Boost)</b>	1410gr	1240gr	1560gr

	RW	E-Flash Carbon 36	E-Flash AL
<b>Rim Material</b>	Aluminium	Full Carbon	Aluminium
<b>Rim Width Inner/Outer</b>	25/29	30 / 36	33 / 37
<b>Profile</b>	22.5	28	21
<b>Tire Size / Width</b>	29" / 2.0 to 2.5	27,5" / 29"	27,5" / 29"
<b>Tire Type</b>	Tubeless ready	Tubeless ready	Tubeless ready
<b>Spoke</b>	Round - J Bend	Round	Round
<b>Nipple</b>	Aluminium	Aluminium	Aluminium
<b>Hub Model*</b>	FSL 3.0	FSL 3.0 Extreme	FSL 3.0 Extreme
<b>Freewheel Body</b>	SH 11 / XD / Micro Spline	SH 11 / XD / Micro Spline	SH 11 / XD / Micro Spline
<b>Braking</b>	Disc Brake IS	IS	Disc Brake IS (6 bolts)
<b>ASTM **</b>	3	3	3
<b>Discipline</b>	XCO / XCM	E-Bikes / AM	E-Bikes / AM
<b>Weight Limit</b>	95kg	110kg	110kg
<b>Weight (Boost)</b>	1690gr	1680gr	2020gr

**Note:** The weights indication is just a reference value.

# TECHNICAL SPECIFICATIONS ROAD DISC WHEELS

	World Tour 5	World Tour 3
<b>Rim Material</b>	Full Carbon UD	Full Carbon UD
<b>Rim Width Inner/Outer</b>	19/26	19/26
<b>Profile</b>	50	38
<b>Tire Size / Width</b>	700x19/28c Tubeless Ready	700x19/28c Tubeless Ready
<b>Tire Type</b>	Clincher / Tubeless Ready	Clincher / Tubeless Ready
<b>Spoke</b>	Aero 2.0	Aero 2.0
<b>Nipple</b>	Aluminium	Aluminium
<b>Hub Model*</b>	Evo R	Evo R
<b>Freewheel Body</b>	SH 10-12s / XDR / Campagnolo	SH 10-12s / XDR / Campagnolo
<b>Braking</b>	Center-Lock	Center-Lock
<b>ASTM **</b>	1	1
<b>Discipline</b>	Road	Road
<b>Weight Limit***</b>	100kg	90kg
<b>Weight</b>	1560gr	1430gr

	Pro Tour Disc 5	Pro Tour Disc 3
<b>Rim Material</b>	Full Carbon	Full Carbon
<b>Rim Width Inner/Outer</b>	21 / 27	21 / 27
<b>Profile</b>	50	30
<b>Tire Size / Width</b>	700x19/28c Tubeless Ready	700x19/28c Tubeless Ready
<b>Tire Type</b>	Tubeless Ready	Tubeless Ready
<b>Spoke</b>	Aero	Aero
<b>Nipple</b>	Aluminium	Aluminium
<b>Hub Model*</b>	FSL R	FSL R
<b>Freewheel Body</b>	SH / XDR / Campagnolo	SH / XDR / Campagnolo
<b>Braking</b>	Center-Lock	Center-Lock
<b>ASTM **</b>	1	1
<b>Discipline</b>	Road	Road
<b>Weight Limit</b>	120kg	110kg
<b>Weight (Boost)</b>	1590gr	1460gr

**Note:** The weights (limit and boost) indication is just a reference value.

\* - Consult hub compatibility in our web site

\*\* - Consult ASTM in our web site

## TECHNICAL SPECIFICATIONS

# TIME TRIAL TRIATHLON WHEELS

### Joker DISC

<b>Rim Material</b>	Full Carbon
<b>Rim Width Inner/Outer</b>	23
<b>Profile</b>	-
<b>Tire Size / Width</b>	700x19/25c
<b>Tire Type</b>	Tubular
<b>Spoke</b>	-
<b>Nipple</b>	-
<b>Hub Model*</b>	SP 2
<b>Freewheel Body</b>	SH / XDR / Campagnolo
<b>Braking</b>	Caliper
<b>ASTM **</b>	1
<b>Discipline</b>	Road
<b>Weight Limit</b>	100kg
<b>Weight</b>	1210gr

## GRAVEL / CYCLOCROSS WHEELS

### CRATER Carbon

### CRATER Carbon Tubular

<b>Rim Material</b>	Full Carbon	Full Carbon   Tubular
<b>Rim Width Inner/Outer</b>	24 / 31	___/28mm
<b>Profile</b>	30	30
<b>Tire Size / Width</b>	28 to 50	28 to 50
<b>Tire Type</b>	Tubeless Ready	Tubeless Ready
<b>Spoke</b>	Inox	Inox
<b>Nipple</b>	Aluminium	Aluminium Black
<b>Hub Model*</b>	FSL R	FSL R
<b>Freewheel Body</b>	SH / XDR / Campagnolo	SH / XDR / Campagnolo
<b>Braking</b>	Center-Lock	Center-Lock
<b>ASTM **</b>	2	2
<b>Discipline</b>	CX / Gravel / Road	CX / Gravel / Road
<b>Weight Limit</b>	110kg	110 kg
<b>Weight</b>	1395gr	1355 gr

**Note:** The weights indication is just a reference value.

\* - Consult hub compatibility in our web site

\*\* - Consult ASTM in our web site

\*\*\* - Weight Limit = rider weight + complet bike



Sealant



Compatible with tubeless ready and full UST wheels/tyres, prevents oxidation in the components.

Capacities: 150ml/500ml/5Lts

MSRP 150ml: 8.90 €  
Ref: P03.04.001

MSRP 500ml: 16.80 €  
Ref: P03.04.002

Center Lock Adapter



The Center lock adapter has been designed to work with the center lock hubs allowing you to fit standard 6 bolt "I.S." conventional disks.

MSRP: 16.80 €  
Ref: P74.99.050

Valve Exten.



Only 1.8 grams per wheel

Material: Aluminum  
Weight: 1.8gr each  
Extend: 32mm  
Color: Black Anodized  
Item: Include 2 pcs

MSRP: 6 €  
Ref: P74.99.001

TR Valves



Removable Core 50% Lighter

Available colors



Material: Aluminum with steel nut  
Weight: 4.2gr  
Height: 44mm  
Rubber Shape: Conic Round  
Color: Black or Red anodized

MSRP: 8.50 €  
Ref. BK 44: P74.99.012  
Ref. RD 44: P74.99.014  
Ref. BK 60: P74.99.034

Removable Core



Material: Brass  
Weight: 8.4gr  
Height: 40mm  
Rubber Shape: Conic Round  
Color: Silver

MSRP: 6 €  
Ref: P74.99.012

TR Rim Tape



Width: 25 / 27 / 30 / 34 / 38 mm  
Length: 5mts

MSRP: 8.75 €  
Ref. 25: P74.99.027  
Ref. 27: P74.99.031  
Ref. 30: P74.99.032  
Ref. 34: P74.99.030  
Ref. 38: P74.99.035

Quick-Rel.



Weight: MTB - 71gr  
Weight: Road - 69gr

MSRP: 32 €  
Ref. Road: P74.99.007  
Ref. MTB: P19.01.008

COMPONENTS  
PHYSIS CARBON

CARBON IS  
IN THE SUN, STARS,  
COMETS AND  
IN YOUR BIKE TOO.

Handle Bar

Material: Carbon UD Matt  
Length: 750mm  
Central Diameter: 31.8mm  
Backsweep: 6.5°  
Weight: 168gr

MSRP: 135 €

Ref: P31.11.004

Seat Post

Material: Carbon UD Matt  
Length: 420mm  
Diameter: 27.2 / 30.9 / 31.6mm  
Min. Insert: 100mm  
Max. Tightness: 5Nm  
Weight (27.2mm): 162gr

MSRP: 155 €

Ref. 27.2: P23.11.014

Ref. 30.9: P22.11.015

Ref. 31.6: P22.11.016

PHYSIS

6

C

12.011

## Handlebar



*The ability to absorb vibrations is critical to reduce fatigue while stiffness is essential for the perfect control of a bike. Though very light, Physis handlebar is rigid and strengthened in grip areas.*

Length: 660mm/710 mm | 730mm (Team)  
Material: Aluminum Light Force  
Weight: 270gr | 210gr (Team)

MSRP: 53 € | 84 € (Team)

Ref. 660: P31.11.001

Ref. 710: P31.11.002

Ref. Team: P31.11.003

## Stem



*Being the stem a key element for the perfect fit for riders' position, Physis stem distinguishes itself by its design, construction materials and vibration absorption capacity.*

Length: 6° and 17° > 80 mm ~ 130mm  
Material: Aluminum Light Force  
Bolts: Titanium  
Weight: 6° - 98gr (90mm) / 17° - 100gr (90mm)

MSRP: 68 €

Ref. 17°: P08.11.010

## Seat Clamp



Dimensions: 31.8 / 34.9 / 36.0 / 38.2  
Material: Aluminum Light Force  
Weight: 5.9gr (38.2)

Available colors



MSRP: 20 €

Ref. 31.8: P04.01.017

Ref. 34.9: P04.01.018

## Bar Ends



Length: 75mm  
Material: Aluminum Light Force  
Weight: 46gr

Available colors



MSRP: 29.50 €

Ref. BK: P25.11.005

## Grips



Material: 100% Silicone  
Weight: 84gr - Comfort / 59gr - Sport

Available colors



MSRP: 18€ (Comf. or Sport)

Ref. BK: P50.01.015

## Seat Post



Length: 410 mm: 100-310mm  
Material: Aluminum Light Force  
Weight: 27.2 x 410 mm > 205 gr  
31.6 x 410 mm > 167 gr  
30.9 x 410 mm > 185 gr

Available colors



MSRP: 95 €

Ref. 27.2: P23.11.004

Ref. 31.6: P23.11.001

Ref. 30.9: P23.11.007



## COMPONENTS

## BOTTOM BRACKET

Our bottom brackets feature high quality sealed cartridge bearings

*The PROTOTYPE bottom bracket is a significant upgrade to any OEM bottom bracket. High quality aluminium material CNC machined cups and the special bearings offer longer bearing life, smoother operation and increase the performance.*

## PF 41-30mm



Axle 30mm (frame 41mm)

MSRP: 46.80 €

Ref: P36.01.012

## PF 41 DUB



DUB (frame 41mm)

MSRP: 43.90 €

Ref: P36.01.018

## PF 41mm



Shimano (frame 41)

MSRP: 37.50 €

Ref: P36.01.010

GXP (frame 41mm)

MSRP: 39.80 €

Ref: P36.01.011

## PF 30mm



BB386 -86.5mm (frame 46mm)

MSRP: 44.80 €

Ref: P36.01.020

DUB (frame 46mm)

MSRP: 44.80 €

Ref: P36.01.017

## PF 30mm



BB30 68-73mm (frame 46mm)

MSRP: 44.80 €

Ref: P36.01.009

Shimano (frame 46mm)

MSRP: 42.80 €

Ref: P36.01.013

GXP (frame 46mm)

MSRP: 42.80 €

Ref: P36.01.014

## PF 42mm



Shimano (frame 42mm)

MSRP: 39.80 €

Ref: P36.01.016

GXP (frame 42mm)

MSRP: 39.80 €

Ref: P36.01.015

## BSA AXLE



Axle 30mm (frame thread)

MSRP: 45.80 €

Ref: P36.01.001

Axle DUB (frame thread)

MSRP: 45.80 €

Ref: P36.01.019

## BSA Shimano



Shimano (frame thread)

MSRP: 37.50 €

Ref: P36.01.003

## BSA-GXP



GXP (frame thread)

MSRP: 39.80 €

Ref: P36.01.005

Headset

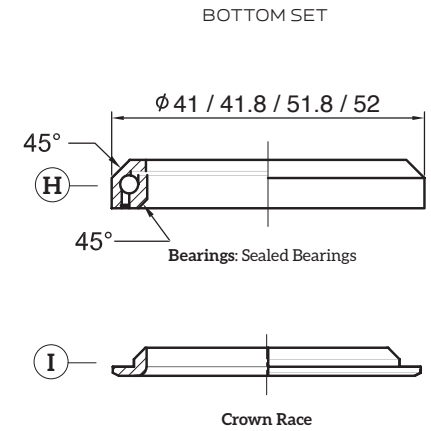
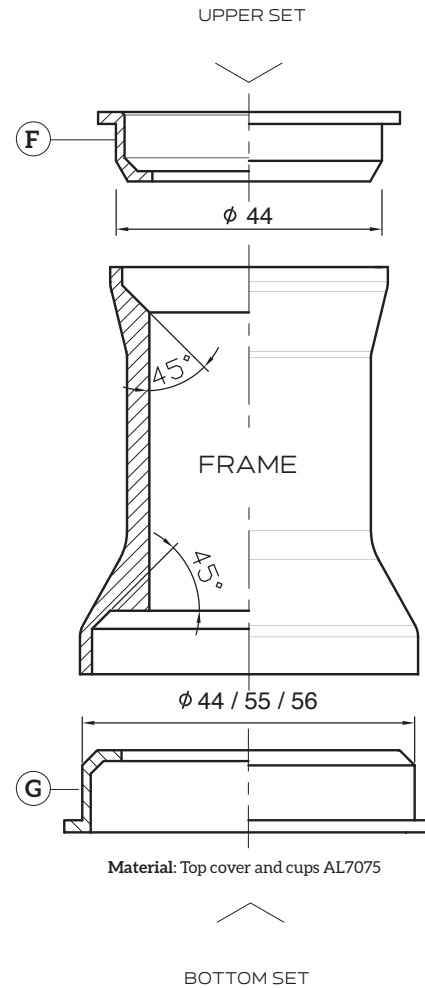
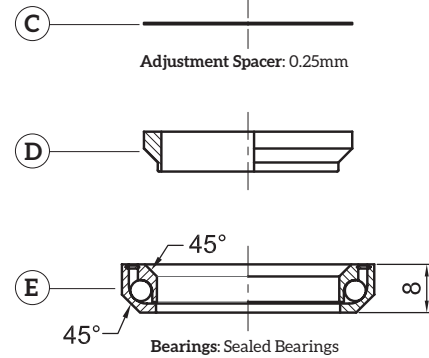
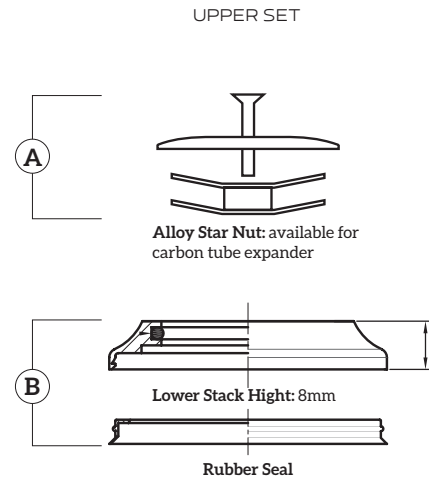

Fork Crown Adaptor

Fork Crown Race Adaptor 1.5" - 1 1/8"



Material: AL7075  
Weigth: 12gr.

MSRP: 6.80 €

Ref: P14.99.001

*The quality of steering headset is assessed by sensivity and smoothness thouthout its lifetime maintenance.*

## COMPONENTS HEADSETS

Prototype headsets have a low profile to keep stack height to a minimum keeping the front end low and fast.

### Semi-integrated

MSRP: 55.90 €	Standard 1 1/8" - 1 1/8"	Tapered 1 1/8" - 1,5" 55mm	Tapered 1 1/8" - 1,5" 56mm
<b>UPPER BEARING</b>	41.8x45°x8	41.8x45°x8	41.8x45°x8
<b>UPPER CUP</b>	44mm	44mm	44mm
<b>BOTTOM CUP</b>	44mm	55mm	56mm
<b>BOTTOM BEARING</b>	41.8x45°x8	51.8x45°x8	51.8x45°x8
<b>Weight without cap</b>	76gr	90gr	90gr

### Integrated

MSRP: 46.80 €	Standard 1 1/8" - 1 1/8"	Standard 1 1/8" - 1 1/8"	Tapered 1 1/8" - 1 1/4"	Tapered 1 1/8" - 1,5"
<b>UPPER BEARING</b>	41.0x45°x8	41.8x45°x8	41.8x45°x8	41.8x45°x8
<b>BOTTOM BEARING</b>	41.0x45°x8	41.8x45°x8	46.8x45°x7	51.8x45°x8
<b>Weight without cap</b>	70gr	72gr	74gr	76gr

### Spacers

#### Super Light headset spacers

Spacers are super light. Featuring CnC machined inner grooves. Not a single gram is spared.



**Material:** Aluminum  
**Outer ø:** 34mm  
**One Set includes 2pcs:** 5 | 10mm  
**Weight:** 5mm: 1.8gr / 10mm: 3.6gr

MSRP: 4.80 €

Ref: P02.01.005 BK

### Headset Cap

#### Headset Top Cap



**Material Cap:** AL7075  
**Material Bolt:** M6x35mm AL7075  
**Material Spider:** AL6061 + Steel  
**Weighth: Top Cap:** 3.8gr  
**Bolt:** 2.3gr / **Spider:** 5.9gr

MSRP: 8.30 €

Ref: P14.99.021 BK

Bearings

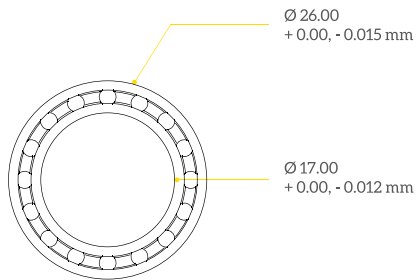

**New EVO Bearings**  
PERFORMANCE, DURABILITY, PRECISION.

**General bearing**

Dimensions	Designation
9 x 17 x 5	689
9 x 24 x 7	609
10 x 19 x 5	6800
10 x 22 x 6	6900
10 x 26 x 8	6000
12 x 21 x 5	6801
12 x 24 x 6	6901
12 x 28 x 8	6001
15 x 24 x 5	6802
15 x 26 x 7	MR15267
15 x 28 x 7	6902
16 x 26 x 7	MR16267
17 x 26 x 5	6803
17 x 28 x 7	MR17287
17 x 30 x 7	6903
18 x 30 x 7	MR18307
20 x 27 x 7	6704
20 x 32 x 7	6804
27.5 x 37 x 7	MR275377 (Predictive)

**High precision ball bearings (Abec5) with hardening surface and anti-corrosion treatment.**



**Headset bearing**

Dimensions	Designation
38.9 x 6.5 x 36°	1-1/8"
39 x 6.5 x 36°	1-1/8"
41 x 6.5 x 45°	1-1/8"
41 x 7 x 45°	1-1/8"
41 x 8 x 45°	1-1/8"
41.8 x 6.5 x 45°	1-1/8"
41.8 x 8 x 30.5 x 45° 1.125T"	1-1/8"
41.8 x 8 x 45°	1-1/8"
46.8 x 7 x 45°	1-1/4"
48.9 x 6.5 x 36°/45°	1-1.5"
51.8 x 8 x 45°	1-1.5"
52 x 8 x 45°	1-1.5"
19/16 x 21 x 9°	Lefty
19/16 x 21 x 9° x 45°	Lefty

**Bottom Bracket bearings**

Dimensions	Designation
22 x 37 x 8/11.5	GXP BSA
24 x 37 x 7	MR24377
25 x 37 x 7	6805
29 x 42 x 7	6806/29 (DUB)
30 x 42 x 7	6806
35 x 47 x 7	6807

Ceramic

Dimensions	Designation
15 x 24 x 5°	6802
15 x 28 x 7°	6902
17 x 26 x 5°	6803
17 x 28 x 7°	MR17287
17 x 30 x 7°	6903
25 x 37 x 7	6805
30 x 42 x 7	6806

**ULTIMAX CERAMIC**





# WORKSHOP

## M5 - M6 Bolts



**Material:** Titanium Gr5

**M5 Dimensions:** 16mm | 20mm | 25mm  
**Weight:** 1,2gr | 1,6gr | 1,7gr

**M6 Dimensions:** 20mm | 25mm | 35mm | 45mm  
**Weight:** 2gr | 2,2gr | 2,5gr | 3,5gr

Available colors



MSRP: 7.50€ (2pcs)

**Ref. M5x16:** P40.01.090

MSRP: 7.50€ (2pcs)

**Ref. M5x18:** P40.01.088

MSRP: 23.50€ (6pcs)

**Ref. M5x8 disc:** P40.01.094

MSRP: 5.90€ (1pc)

**Ref. M5x30:** P40.01.099

MSRP: 14€ (2pcs)

**Ref. M6x18:** P40.01.097

MSRP: 23.5€ (4pcs)

**Ref. M6x18:** P40.01.096

## Chaining Bolt



**Material:** Aluminum Light Force

**Small** 6,5mm  
**Weight:** 5,8gr

**Large** 8,5mm  
**Weight:** 7gr

Available colors



MSRP: 14.50€ (4pc)

**Ref. 6.5 mm:** P40.01.064

MSRP: 18€ (5pcs)

**Ref. 6.5 mm:** P40.01.069

MSRP: 23.5€ (4pcs)

**Ref. 8.5 mm:** P40.01.074

MSRP: 18€ (5pcs)

**Ref. 8.5 mm:** P40.01.079

## Bolt SRAM M10



**Material:** Aluminum Light Force

**Weight:** 4,1gr

Available colors



MSRP: 25€ (4pc)

**Ref:** P40.01.084 BK

Visit [www.prototype.pt/support](http://www.prototype.pt/support)  
to find:

WARRANTY POLICY  
 MANUALS  
 CATALOGS



**PROTOTYPE**<sup>™</sup> BICYCLE RACING PARTS

WWW.PROTOTYPE.PT

# TRUE HEROES TRUE INSPIRATION

V 2024.1

PROTOTYPE | Leiria-Portugal  
hello@prototype.pt | [www.prototype.pt](http://www.prototype.pt)



**Telmo Pinão**  
Olympic Para-Cycling Athlete